

Small Explorer Program  
 Aeronomy of Ice in the Mesosphere  
 (AIM)

**AIM Data Management Plan**

AIM-DMP-03-1

Date: April 1, 2005

Revisions				
Rev	Description of Change	By	Approved	Date
	Initial Release	J. Burton		12/18/01
0	Version 0 for PDR	J. Burton		01/21/04
1	Version 1 for CDR	J. Burton		11/5/04
2	Version for MOR	J. Burton		04/01/05

## Signature Page

**Prepared by:**

\_\_\_\_\_  
John C. Burton  
AIM Science Data Systems Manager

**Concurred by:**

\_\_\_\_\_  
David Welch  
AIM Mission Operations Manager

\_\_\_\_\_  
Cindy Russell  
CIPS/CDE Data Systems Manager

\_\_\_\_\_  
Randal Davis  
AIM Ground Data Systems Manager

**Approved by:**

\_\_\_\_\_  
Mary Bolton  
AIM Project Manager

\_\_\_\_\_  
Scott M. Bailey  
AIM Deputy Principal Investigator

\_\_\_\_\_  
James M. Russell III  
AIM Principal Investigator

## Table of Contents

<b>1</b>	<b>INTRODUCTION .....</b>	<b>1</b>
1.1	AIM PROGRAM OVERVIEW.....	1
1.2	DOCUMENT PURPOSE AND SCOPE .....	1
1.3	DOCUMENT LIFECYCLE.....	2
<b>2</b>	<b>REFERENCED DOCUMENTS.....</b>	<b>2</b>
<b>3</b>	<b>AIM DATA SYSTEM OVERVIEW.....</b>	<b>2</b>
3.1	SCIENCE DATA SYSTEM (SDS) .....	2
3.2	SDS SCOPE .....	3
3.3	SDS LIFECYCLE.....	4
<b>4</b>	<b>SDS ORGANIZATION.....</b>	<b>4</b>
4.1	SDS FACILITIES .....	4
4.2	FACILITY RESPONSIBILITIES .....	5
<b>5</b>	<b>SDS STANDARDS AND POLICIES.....</b>	<b>6</b>
5.1	DATA ACCESS POLICY .....	6
5.2	GUIDELINES FOR DATA USE.....	6
5.3	SDS INTERNAL STANDARDS AND POLICIES .....	7
5.3.1	<i>Data formats .....</i>	<i>7</i>
5.3.2	<i>Communications methods .....</i>	<i>7</i>
5.3.3	<i>Data security.....</i>	<i>7</i>
5.3.4	<i>Interface control.....</i>	<i>7</i>
5.3.5	<i>Computer system standards .....</i>	<i>8</i>
5.3.6	<i>Time and geometry representation standards.....</i>	<i>8</i>
5.3.7	<i>Internal delivery schedules .....</i>	<i>10</i>
5.3.8	<i>Configuration management .....</i>	<i>10</i>
5.3.9	<i>Corrective action process .....</i>	<i>11</i>
5.3.10	<i>Data quality assurance .....</i>	<i>14</i>
5.4	SDS EXTERNAL STANDARDS AND POLICIES .....	14
5.4.1	<i>Distribution formats.....</i>	<i>14</i>
5.4.2	<i>Data availability .....</i>	<i>14</i>
<b>6</b>	<b>AIM DATA PRODUCTS.....</b>	<b>15</b>
6.1	PRODUCT CLASSIFICATION .....	15
6.1.1	<i>Generation method classification .....</i>	<i>15</i>
6.1.2	<i>Data content classification .....</i>	<i>15</i>
<b>7</b>	<b>SDS CONCEPT.....</b>	<b>16</b>
7.1	USER TYPE PRODUCT REQUIREMENTS .....	16
7.2	DATA SOURCES.....	17
7.3	SYSTEM ARCHITECTURE .....	17

7.3.1	<i>Functional data flow</i> .....	17
7.3.2	<i>Long term archive preparation</i> .....	18
7.3.3	<i>Shared software</i> .....	19
<b>8</b>	<b>INTERNET SERVICES</b> .....	<b>19</b>
8.1	MISSION PLANNING AND OPERATIONS.....	19
8.2	DATA PRODUCTS .....	19
8.3	SHARED SOFTWARE .....	20
8.4	INSTRUMENT/SCIENCE TEAMS .....	20
8.5	EDUCATIONAL AND PUBLIC OUTREACH .....	20
8.6	PERSONNEL DIRECTORY .....	20
8.7	MISSION RELATED PUBLICATIONS.....	20
<b>9</b>	<b>DATA PRODUCTS</b> .....	<b>20</b>
9.1	DATA PRODUCT REQUIREMENTS .....	20
9.1.1	<i>Science teams requirements</i> .....	20
9.1.2	<i>Scientific community requirements</i> .....	21
9.1.3	<i>General public requirements</i> .....	21
9.1.4	<i>K-14 educators requirements</i> .....	21
9.2	MEASUREMENT DESCRIPTIONS .....	21
9.2.1	<i>CIPS</i> .....	21
9.2.2	<i>CDE</i> .....	21
9.2.3	<i>SOFIE</i> .....	21
9.3	DATA PRODUCT DESCRIPTION .....	22
9.4	REQUIREMENTS ALLOCATION.....	25
9.5	DATA RATES.....	26
	<b>APPENDIX A - DATA PRODUCT SPECIFICATION</b> .....	<b>28</b>
	<b>APPENDIX B - AIM VERSIONS AND REVISIONS</b> .....	<b>31</b>
B.1	DATA PRODUCT REVISION NUMBER .....	31
B.2	DATA PRODUCT VERSION NUMBER.....	31
B.1.1	<i>Product Format Version Number</i> .....	31
B.1.2	<i>Software Version Number</i> .....	31
B.1.3	<i>Input/Cal Version Number</i> .....	31
	<b>APPENDIX C - ACRONYMS AND DEFINITIONS</b> .....	<b>32</b>

# 1 Introduction

## 1.1 AIM Program Overview

Over the last 30 years ground based and satellite-based observations of the number of noctilucent clouds (NLCs) show dramatic increases. These clouds are believed to respond dramatically to even small changes in their environment. Since cooling of the upper atmosphere (PMCs occur near 85 km) is expected to accompany the possible warming of the lower atmosphere due to an increased greenhouse effect, an increase in mesospheric cloudiness could be one consequence of mesospheric climate change. If the reported NLC increases are truly representative of the entire polar region, then this beautiful sky phenomenon may be our most visually obvious manifestation of anthropogenic change in the atmosphere.

The overall goal of the Aeronomy of Ice in the Mesosphere (AIM) experiment is to resolve why PMCs form and why they vary. By measuring PMCs and the thermal, chemical and dynamical environment in which they form, we will quantify the connection between these clouds and the meteorology of the polar mesosphere. In the end, this will provide the basis for study of long-term variability in the mesospheric climate and its relationship to global change. The results of AIM will be a rigorous validation of predictive models that can reliably use past PMC changes and present trends as indicators of global change. This goal will be achieved by measuring PMC abundances, spatial distribution and particle size distributions, gravity wave activity, dust influx to the atmosphere and precise, vertical profile measurements of temperature, H<sub>2</sub>O, CH<sub>4</sub>, O<sub>3</sub>, CO<sub>2</sub>, NO, and aerosols. These data can only be obtained by a complement of instruments on an orbiting spacecraft (S/C).

In order to achieve the goals of the mission, data collected, generated, and analyzed as part of the AIM program must be shared among AIM investigators, the scientific community and the general public. The AIM Science Data System (SDS) will provide the mechanism through which the data collection, processing, validation, archival and sharing will take place.

## 1.2 Document Purpose and Scope

This document describes the AIM Science Data System (SDS), its structure, its policies and its products. This document provides

- Information for users about the SDS, including an overview of what products are available and how access is provided.
- Guidelines and specific technical information to the SDS implementation teams to aid in construction of the data system.
- Information useful for evaluation of the SDS by AIM program management and the NASA Data System review team.

Much of the detail required for the use, implementation and evaluation of the SDS is referenced rather than repeated here.

### 1.3 Document Lifecycle

This is a working document. The amount of detail contained in this document will increase as the SDS is developed and the AIM program matures. Five major versions of this document are planned.

- Version 0 - This preliminary version has been used as a planning tool during mission design. The SDS manager made changes during this time when necessary. Concurrence signatures were obtained by the time of the Preliminary Design Review.
- Version 1 - This will be the first signed version of this document and will be subject to standard change control procedures. It will be available for signature at the Mission Critical Design Review.
- Version 2 - This version will be signed and available approximately 6 months before the AIM spacecraft is launched.
- Version 3 - This version will be signed and available 1 year after the AIM spacecraft is launched. It will reflect any changes made to accommodate flight operations.
- Version 4 - This version will be signed and available 3 months after termination of the spacecraft operations phase (December, 2008). The main purpose of this version is to provide mission closeout refinements.

## 2 Referenced Documents

- AIM Science Data System Interface Control Document, G&A Technical Software, Inc., AIM-SDS-ICD-03-1.V0, Dec 2003
- AIM MOC External Interface Control Document, CU/LASP,

## 3 AIM Data System Overview

The AIM project will use two complementary data systems, the Mission Operations Data System (MODS) and the SDS. The MODS consists of systems needed to command, control, and monitor the AIM spacecraft and instruments, and will fall under the authority of the Mission Operations Manager at LASP / CU. Definition and description of the MODS is outside the scope of this document. This document focuses on the SDS, which is responsible for processing the instrument data into data products useful to AIM program elements and other interested groups.

### 3.1 Science Data System (SDS)

The AIM SDS is responsible for the acquisition, generation, distribution, and archival of science data necessary to support the AIM mission. In this capacity, the SDS will provide useful data products to the AIM program elements, the scientific community, K-14 educators and the general public.

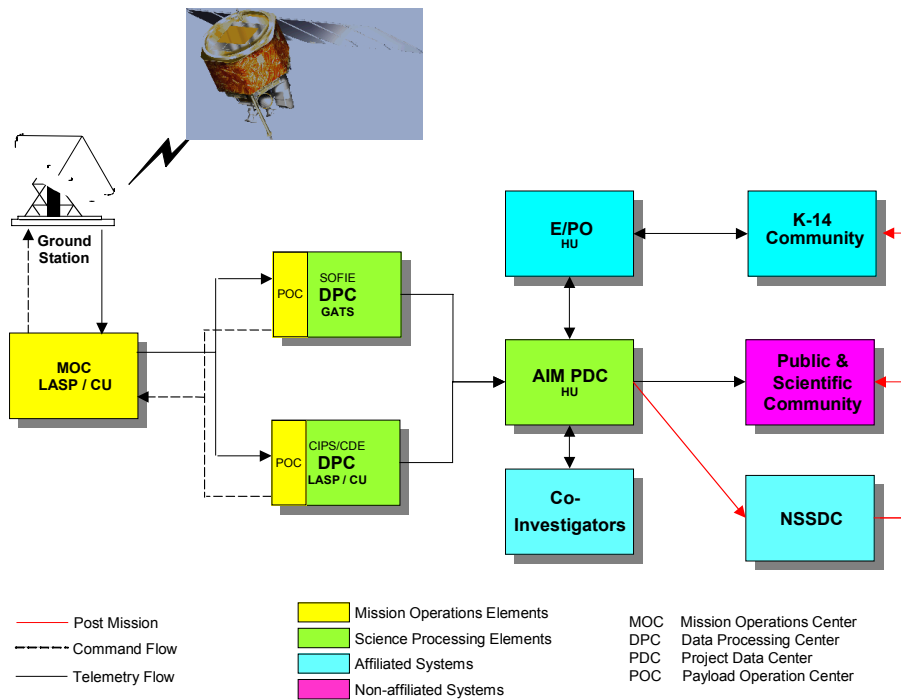

**Figure 3-1 AIM Science Data System**

**Figure 3-1 AIM Science Data System** shows the various AIM program elements and external users of the SDS. The SDS will supply data to both AIM program elements and external users. AIM program elements require science data products as input to instrument operations and data analysis. For external users (i.e. the scientific community and the public), the AIM SDS is the principal means of access to AIM data products during the course of the mission.

The AIM program is required to prepare a final version of its data products and will archive the data in the National Space Sciences Data Center (NSSDC). The SDS will be responsible for this delivery at mission closeout, currently planned for Sept 2008.

### 3.2 SDS Scope

The functions of the AIM SDS are distributed over several facilities. The SDS manager coordinates these functions. Many SDS facilities support functions that are not related to the data system. Only functions that are directly related to the routine production, acquisition, archival or distribution of data are within the scope of the SDS. Functions that pertain to satellite and/or instrument operations fall under the scope of the Mission Operations Data Systems (MODS) and are detailed in a separate document. The Mission Operations Manager at LASP / CU will coordinates these functions.

The SDS manager is responsible for coordinating the development and operations of SDS functions resident at the various facilities. Each facility is responsible for developing the

portion of the SDS that it will operate, subject to the standards, policies and interface constraints supplied by the SDS manager. The SDS manager will not monitor details of facility implementations unless they impact the development or operations of other SDS facilities or the operations of the data system as a whole

### 3.3 SDS Lifecycle

There will be three major phases of the SDS lifecycle.

- **Pre-launch phase** - During this phase, the SDS will be fully defined and implemented. Elements that support project communication, such as document access systems will be implemented early. However, this should be regarded as a system development phase rather than an operational phase.
- **Mission operations phase** - This phase is defined as the time during which the AIM instruments are acquiring data on orbit. During this period, it is the program's responsibility to supply data to AIM program elements, the scientific community, general public and K-14 educators through the PDC and instrument DPCs. The bulk of this document describes the SDS during spacecraft operations.
- **Post orbital data analysis and mission closeout phase** – This phase begins at the end of AIM mission operations and continues through mission closeout. During this period data products will be refined and the program will prepare a final version of the AIM data products and related software for archival and provide it to the National Space Sciences Data Center (NSSDC). During this phase, the AIM program will continue to supply data to the various user communities. After the final data version and supporting documents are delivered, it will be the responsibility of the NSSDC to manage and deliver data to users.

## 4 SDS Organization

### 4.1 SDS Facilities

The AIM SDS is a distributed system with elements that are part of several different facilities. These facilities are listed in *Table 4-1 AIM Data System Facilities*. The SDS manager at Hampton University coordinates the SDS elements at these facilities.

**Table 4-1 AIM Data System Facilities**

Facility Name	Location	Data System Lead
AIM Mission Operations Center (MOC)	LASP / CU	R. Davis
AIM Project Data Center (PDC)	Hampton University	J. Burton
SOFIE Payload Ops & Data Processing Center (POC-DPC)	GATS	J. Burton
CIPS Payload Ops & Data Processing Center (POC-DPC)	LASP / CU	C. Russell
CDE Payload Ops & Data Processing Center (POC-DPC)	LASP / CU	C. Russell

The AIM Mission Operations Center (MOC) is the central facility responsible for satellite operations and telemetry distribution. The instrument Payload Operations Center (POC)



located at the instrument Data Processing Center (DPC) serves as the demarcation point between the MODS and the SDS. Only the portion of the POC involved with telemetry distribution falls within the scope of the SDS. The remaining portions fall within the scope of the MODS.

## 4.2 Facility Responsibilities

The AIM MOC will be responsible for:

- Initial processing and distribution of spacecraft and instrument telemetry.
- Playback distribution of spacecraft and instrument telemetry.
- Archival (during the mission) of all raw and level 0 telemetry data.
- Maintaining planned and as-run timelines for spacecraft and instruments.

Each POC will be responsible for:

- Supplying the MOC with instrument planning and as flown status information.
- Archiving the level 0 data for their instrument.
- Producing data quality assessments for their instrument.
- Producing instrument state of health information for short-term limits, configuration, long-term trends, and performance analysis.

Each instrument DPC will be responsible for:

- Producing, managing, and archiving the level 1-4 products for their instrument.
- Producing, managing, and archiving the survey data products for their instrument.
- Managing and archiving the analysis data products generated by the science team associated with their instrument.
- Providing necessary data processing support for the science team associated with their instrument.
- Supplying the PDC with data product metadata and generation status information.
- Disseminating the science data products for their instrument, as well as information and documentation pertaining to their instrument, to the scientific community and public.
- Supplying data product holdings to the PDC for inclusion in the final archive.
- Participating in the review of the final archive.

The AIM PDC will be responsible for:

- Providing a meta-data catalog of all the AIM science data products with links (URLs) to the appropriate dissemination facility, to the scientific community and public.
- Producing, managing, and archiving the Common Volume Observation (CVO) data products.
- Disseminating the CVO data products to the scientific community and public.
- Maintaining information about available data products and data quality.
- Producing the long-term data set and supporting documents and delivering them to the final archival facility.

## 5 SDS Standards and Policies

AIM will utilize a distributed data processing, dissemination and management architecture. All standards, policies and guidelines suggested here are subject to revision and approval by the AIM project team

### 5.1 Data Access Policy

Data products generated by the AIM project as defined by this document will be considered non-proprietary and will be placed in the public domain. It is recognized that providing documentation, media and electronic transmission capability requires funding. Therefore, access to data products not described in this document will be at the discretion of the project or PI.

Table 9-1 AIM Data Products contains a list of higher-level data products that will be made available. Furthermore, the complete level 0 data set shall be made available to the public, along with sufficient documentation, to use this data independently. A timetable for the release of these products will be submitted for approval.

During the life of the AIM mission, the project will be responsible for distributing data to the scientific community and the general public. During this period, level 2 and higher products will be routinely made available to the public and independent researchers. Scientific users of AIM data will be encouraged to register as users so that they may be kept informed of any changes and enhancements that may effect their use of the data.

Any publication incorporating AIM data products must acknowledge the contribution of the AIM program.

### 5.2 Guidelines for Data Use

Users of AIM data are asked to respect the following guidelines:

- Mission scientific and model results are open to all users.
- Users should contact the AIM PI or a designated PI of an instrument or modeling group early in an analysis project to discuss the appropriate use of instrument data or model results. This applies to AIM mission team members, any guest investigators, and other members of the scientific community and general public.
- Users that wish to publish the results derived from AIM data should normally offer co-authorship to the AIM PI, Deputy PI and/or instrument PIs and science team members. Co-authorship may be declined. Appropriate acknowledgement to institutions, personnel, and funding agencies should be given.
- Users should heed the caveats of investigators as to the interpretation and limitations of data or model results. Investigators supplying data or models may insist that such caveats be published, even if co-authorship is declined. Data and model version numbers should also be specified.
- Pre-prints of publications and conference abstracts should be widely distributed to interested parties within the mission and related projects.

### 5.3 SDS Internal Standards and Policies

This section describes the standards and policies relevant to the internal interfaces of the SDS. These policies and standards are meant to apply to communications between SDS facilities. They do not apply to the internal interfaces within individual facilities or communication between PIs and their Co-investigators.

#### 5.3.1 Data formats

While it is understood that one data format cannot satisfy the needs of all aspects of a complex project such as AIM, the format of data exchanged between facilities must be in a common format that can be easily interpreted by all. A preliminary list of suggested data formats include:

**Table 5-1 Data Formats**

<b>Data Type</b>	<b>Acceptable Formats</b>
Raw telemetry	CCSDS Transfer Frames
Level 0	CCSDS Packets
Level 1 & higher science data products	NetCDF
Status reports & other small products	Well formatted ASCII text
Images & graphics	PNG, JPG, PDF, Postscript
Animations	MPEG

#### 5.3.2 Communications methods

Communications between elements of the AIM Data Systems fall into two primary categories: privileged and unprivileged. Communications between SDS and MODS elements would be considered privileged and utilize SCP, HTTP, and SMTP protocols over SSL and SSH based secure channels. E-mail would also be digitally signed for authentication. Communications between the SDS and public and educational outreach elements would be considered unprivileged and handled via FTP, HTTP, and SMTP protocols over standard, non-secure channels.

#### 5.3.3 Data security

Each SDS facility is responsible for protecting the data that they archive from loss, corruption and malicious tampering. Adequate security and backup/recovery mechanisms will be established if not already present and adequately documented. The backup/recovery mechanisms will detail contingency plans to ensure a full recovery from catastrophic damages/failure. At a minimum this will include offline and offsite backup of data and software. The security procedures will also ensure only released products are accessible and the accessible products are in fact valid released products.

#### 5.3.4 Interface control

All routine interfaces between SDS facilities will be documented with an interface control document (ICD). Each document will require the signatures of:

- The manager of each facility governed by the ICD

- The AIM Principal Investigator
- The AIM program manager
- The AIM SDS manager

The contents of these documents will include, but are not limited to

- Identification of the facilities supporting the interfaces
- Identification and qualitative descriptions of the interfaces to be supported
- The communications methods to be used
- Detailed description of the data products to be transferred
- Data delivery schedules
- Qualification methods
- Requirements traceability

### **5.3.5 Computer system standards**

While there will be no official AIM standard computer platform specified, the use of COTS (commercial off the shelf) hardware and OS (open source) software is encouraged, where appropriate, to minimize costs and promote the open exchange of software technology. The processing needs of the various instruments have been determined to be relatively modest and well within the capability of current COTS systems

### **5.3.6 Time and geometry representation standards**

Data products exchanged among AIM facilities, and with external users should represent time, coordinate systems, attitude and pointing in a standard manner. These quantities may also be represented in other ways, providing the standard representations are also included in the data product.

#### **5.3.6.1 Time representation**

The AIM SDS will support two representations of time. A binary format will be used for computer readable files. A text format will be used in filenames and human readable files (e.g. text files).

The binary time representation will consist of a 32-bit integer containing the number of seconds elapsed since January 6, 1980, the epoch used by GPS. A millisecond (16 bit) or microsecond (32 bit) vernier will be supplied to the extent the resolution is available and necessary.

The text time will be given in UTC and have the following format:

YYYYDOYHHMMSS\_XXXXXX

Where:

YYYY – Four-digit year  
DOY – Day of the year  
HH – Hour of the day  
MM – Minute of the hour  
SS – Second of the minute

XXXXXX – microsecond of the second

If all fields are not necessary for a particular application, it is acceptable to use only those fields deemed necessary. The use of a 2-digit year representation is strongly discouraged.

### 5.3.6.2 Coordinate systems

Inertial coordinates should be referenced to the ECI J2000 coordinate system with X, Y, and Z in units of km. For positions in the celestial sphere, right ascension and declination will be in decimal degrees.

Positions in the Earth referenced coordinate system should be in terms of longitude (0-360 degrees east), latitude, and altitude (km). Latitude and altitude should reference the WGS ellipsoid where:

- Mean radius = 6378.1370 km
- Flatness parameter =  $1/(298.25722356)$

### 5.3.6.3 Attitude and pointing

In general, data products should contain both inertial and earth referenced attitude/pointing information. Below are standard methods for specifying pointing.

Inertial Quaternion: A quaternion that will transform coordinates in the spacecraft frame of reference to the ECI J2000 system.

Earth fixed attitude: Yaw, pitch and roll angles referenced to the coordinate system given below under ‘Earth referenced line of sight’.

RA and DEC of line of sight: Right ascension and declination of the intersection of the line of sight with the celestial sphere. A roll angle in degrees may also be supplied if necessary.

Unit vectors: A unit vector specifying the line of sight direction in J2000 coordinates.

Earth-referenced line-of-sight: The earth-referenced line-of-sight is defined in the topocentric local tangent frame (North-East-Down) defined with origin at the spacecraft center of mass. The reference plane is the plane normal to the line from the earth center to the spacecraft, the local horizontal plane. The x-axis is in the reference plane pointing north, the y-axis is in the reference plane pointing east, and the z-axis is normal to the reference plane pointing towards the earth center.

The line-of-sight direction is defined by an azimuth angle and an elevation angle. The azimuth angle is the angle in the reference plane measured from the x-axis to the projection of the line of sight on the local horizontal plane. It increases in the right hand sense about +z, that is it increases from the x-axis toward the y-axis. The elevation angle is the angle from the reference plane to the line of sight. The elevation angle is zero when the line of sight is in the reference plane and 90 degrees when the line of sight points toward the earth center.

Earth-referenced look point: The longitude, latitude, and altitude of the point where the line-o-sight either intersects the Earth’s surface, or the position of the minimum ray

height to the geoid (the ‘look point’). This cannot be used for observations above the local horizon. Intersections of the line-of-sight with a surface that is a fixed distance above the geoid may also be used if the fixed distance is clearly specified.

### **5.3.7 Internal delivery schedules**

Internal delivery schedules will be documented in the ICDs described in section 5.3.4, subject to the following constraints.

1. Level 0 data will be available to the POCs within 40 hours after its acquisition on orbit.
2. An initial version of a facility’s routine products will be available within 56 hours after acquisition by the POC.
3. During the first 6 months of the mission, delivery timelines for routine level 1 and higher products will not apply.

### **5.3.8 Configuration management**

The SDS is expected to change over the life of the AIM mission. For this reason, we will implement a configuration management process to control the changes of key aspects of the SDS. These aspects are as follows:

- Data product specifications
- Data product requirements
- ICDs and other data system documents (including this document)
- Final archive products
- URLs that are part of the SDS

A baseline configuration will be developed for each one of these aspects, and changes to the baseline will be tracked and managed. As a result of this process, we will be able to describe the current state of these items at any point during the program as well as past states. Changes to the configuration will be made through the corrective action process.

#### **5.3.8.1 Data product specification**

For AIM, the configuration of data product specifications will be controlled, rather than the data products themselves. Each data product managed by the SDS will have a data product specification. These specifications will be used as aids for data location, data product descriptions and as an aid to interface control. Appendix A contains a discussion and description of the data product specification.

The configuration of product specifications is controlled through the Data Product Version and Version Description fields in the specification. Conventions for version numbers are given in Appendix B. Only changes that require a modification of the Data Product Version number are subject to the corrective action process that is described below.

#### **5.3.8.2 Data product requirements**

Data product requirements, shown in section 9.1, will be placed under configuration management as well. Upon full signature approval of this document, the requirements described in this DMP will be considered the initial baseline. Changes will be managed through the corrective action process. A full description of the requirements will be available from the SDS manager. Subsequent releases of this document will contain the most recent version of the requirements available at publication.

### 5.3.8.3 ICDs and other SDS documents

In view of the distributed nature of the SDS, we expect that various facilities will produce documents that are important for the SDS to track. The facility that originates the document should conduct version management. Naming conventions will be adopted from the originating facility, though for SDS purposes, the name of the originating facility will be placed before the facility specific version number. This allows the documents that are relevant to the SDS to be tracked uniquely without having to rename or re-version the documents. The SDS manager will maintain a library of these documents.

### 5.3.8.4 Final data products and supporting documents

Each delivered release of the final data set and supporting documents will be placed under configuration management. Master copies will be kept by the PDC. No changes to the archives will be made between releases. The version naming convention will be developed as part of the final archival planning.

### 5.3.8.5 SDS URLs

URLs that are part of the SDS will be tracked by the PDC to assure clean connectivity within the system. Changes will be made according to the corrective action process below. For URLs the corrective action process is directed toward notification of users rather than SDS content or revision control.

## 5.3.9 Corrective action process

When problems are found with data products, documents, or other configuration items of the SDS, the corrective action process will be used to address them. The corrective action process is used to modify any of the items under configuration management. This process is closely tied to the configuration management process described above. For AIM, corrective action will take place in three stages

- Problem Reporting
- Change Management
- Change Notification

The details of the corrective action process will depend upon the type of configuration item being changed. The SDS manager will track the status of change during the entire process.

### 5.3.9.1 Problem reporting

The problem reporting system will be used to signal problems in the data products or the user interface. Upon identifying a problem (or suspected problem), the user should complete a Problem Report Form. This form will be available for electronic submission and contain the information listed in Table 5-2 Problem Reporting Fields

**Table 5-2 Problem Reporting Fields**

Field Name	Required / Optional	Description
Submitted by	R	Name of person filing the problem report
Date	R	Date submitted
Email Address	O	Email address where problem status reports should be sent

Phone	O	Phone number of person submitting the problem report
Data Product Name	O	Name of the offending Data Product
Problem URL	O	URL of the offending interface page
Problem Description	R	Detailed text description of the problem

Problem reports are submitted to the SDS manager. Upon receipt of the problem report, the SDS manager will assign a tracking number to it. If the person that submitted the report included an email address, the tracking number will be sent to that address. The SDS manager will maintain a list of open problem reports. The manager of the facility responsible for the configuration item in question will be informed of the problem. At this point, the facility manager in conjunction with the SDS manager will decide if the problem indicated will require a modification or change controlled under the formal change management procedure. The criteria for change management are listed in the next section. The majority of problems likely will not qualify and can be handled informally with the facility manager responsible for tracking resolution activities. In the event that the problem report does qualify for formal change management, the facility manager will respond with a change request or a change notification. In either case a status message is then sent to the email address on the original problem report. The following two sections apply only to the small subset of problems / changes listed in the next section.

#### 5.3.9.2 Change management

Formal change management will be practiced on configuration items that need to be reviewed before modifications are made. This process will only apply to:

- Changes in content to ICDs and other SDS documents
- Major data product version changes
- Changes to controlled requirements

Additions and deletions to the list of AIM Data Products require a change to the SDS documentation and are governed by this process.

Note that minor changes to data product software and calibrations do not need to undergo change management at the SDS level. Only changes that modify the format of the data product or reflect substantial changes in processing algorithms or calibrations are subject to this process.

Changes to ICDs and other SDS documents will be done in accordance with the revision and signature processes particular to their originating facility. Major data product version changes and the modification of the SDS requirements will be made via the change request process described below.

The initiator of a change will fill out and submit a change request form to the SDS manager. This change form will be available electronically. The contents of this form are described in Table 5-3:

**Table 5-3 Change Request Fields**

Field Name	Required / Optional	Description
------------	---------------------	-------------



Submitted by	R	Name of person filing the change request / problem report
Submission date	R	Date submitted
Email address	R	Email address where change request / problem report status reports should be sent
Phone	O	Phone number of person submitting the change request / problem report
Problem report	O (R)	If this change is in response to a problem report, its number becomes required and goes here.
Item to be changed	R	Data product specification or requirement to be changed
Description of change	R	Detailed description of the change, including references as needed.
Justification for change	R	Reason that this change should be made
Proposed date of change	O	Date when this change should go into effect
Impact of change	O	Approximate cost / resource impact of the change

Upon receipt of the change request, the SDS manager will assign a tracking number and report this number to the requestor. The change will then be presented to the Change Control Board, which will consist of a representative of each SDS facility, the SDS manager and the AIM Principal Investigator. Although this board may have periodic meetings, the review of change requests will be done via email, telephone or conference calls. The SDS manager will coordinate change request reviews. Board members will review change requests for possible program and/or facility impact. Board members will be encouraged to submit written opinions. These opinions will be sent to the initiator of the change and recorded by the SDS manager. The decision on whether to proceed with a change will be made by board consensus. The AIM Principal Investigator will have final approval on all changes.

**5.3.9.3 Change notification**

Before any change is made to configuration items, SDS facilities and users will be notified via the change notification process. Facilities are also encouraged to use this process for minor releases of data product versions as well. At least one week before a change goes into effect, the facility responsible for making the change should submit a change notification to the SDS manager. This form will be available electronically. The contents of this form are described in Table 5-4.

**Table 5-4 Change Notification Contents**

Field Name	Required / Optional	Description
Submitted by	R	Name of person filing the change notification / problem report
Submission date	R	Date submitted
Email address	R	Email address where status reports should be sent

Phone	O	Phone number of person submitting the change notification / problem report
Problem report	O (R)	If this change is in response to a problem report, its number becomes required and goes here.
Item to be changed	R	Data product specification or requirement to be changed
Description of change	R	Detailed description of the change, including references as needed.
Justification for change	R	Reason that this change should be made
Proposed date of change	O	Date when this change should go into effect
Impact of change	O	Approximate cost / resource impact of the change

Upon receipt of the change notification, the SDS will assign a tracking number and report this number to the requestor. The SDS manager will then forward this notification to all appropriate parties. The SDS manager will also track all change notifications during the life of the program.

### 5.3.10 Data quality assurance

The SDS manager will routinely sample data product format, content, transmission method and timing. Data products will be selected and audited at random. The SDS manager will track the results of these audits. Problems encountered during these audits will be reported to the responsible facility, and, if necessary, a problem report will be filed.

## 5.4 SDS External Standards and Policies

These standards and policies govern the interfaces that SDS facilities maintain with facilities that are not part of the SDS.

### 5.4.1 Distribution formats

Public distribution formats will be the same as the internal data formats listed in Table 5-1.

### 5.4.2 Data availability

Each SDS facility will maintain an on-line area for the public distribution of their data products. This area should be large enough to hold, at a minimum, the currently released version of their routine data products. The goal bandwidth for data transfers to the public should be at least 1MB/sec. Facilities should budget at least 2 hours of transfer time per day. Larger data orders may need to be separately negotiated.

We expect from time to time, circumstances will not permit the above availability requirements to be met, due to

- Network availability or bandwidth problems
- System administration tasks and problems
- Hardware failures
- High priority events

In these events, the requirements will be relaxed. We do not budget for redundancy.

Each facility is expected to plan for downtime and reprocessing. Downtime should be less than 4 hours per day for routine processing and less than 1 day per month for data distribution. Distribution to the public is expected to run unattended and be available continuously, with a minimum up-time requirement of 12 hours per day.

The AIM Principal Investigator, assisted by the Deputy PI and AIM Co-investigators shall be responsible for initial analysis of the data, its subsequent delivery to the National Space Sciences Data Center (NSSDC) data repository, the publication of scientific findings, and communication of results to the public. Additionally, the AIM Principal Investigator shall be responsible for collecting engineering, and ancillary information necessary to calibrate and validate the scientific data prior to depositing it in the NSSDC. The time required to complete this process shall be the minimum necessary to provide accurate, validated scientific data to the science community and the general public but no later than six months after satellite commissioning. The AIM science database shall be made available to the science community without restrictions or proprietary data rights of any kind.

During the first six months of the mission after commissioning, timelines for the release of level 1 and higher products do not apply.

## 6 AIM Data Products

### 6.1 Product Classification

There are two important attributes to be captured by the classification scheme:

- How the data is generated
- What information is contained

#### 6.1.1 Generation method classification

The Product Generation Classification is used to determine delivery schedules and aid in system monitoring

Generation Class	Description
Routine	Produced regularly and systematically with a minimum of human intervention
Analysis	Produced as the result of data analysis or other human intensive process
On-demand	Produced on demand from a user request

#### 6.1.2 Data content classification

Data Content Classes are used to refer to the type of data contained in the product. Data levels are adapted from the EOS Handbook. The data levels are supplemented with additional product content classes for products that are not easily classified by the data level scheme.

Content Class	Description
Raw Telemetry	Unprocessed digital telemetry
Level 0	Unprocessed instrument data at full resolution that has been separated by instrument or subsystem – time ordered with duplication removed
Level 1	Instrument data at full resolution, time-referenced and annotated with ancillary information including geometric parameters, that has been processed to radiometric / scientific units
Level 2	Derived geophysical parameters at the retrieval resolution
Level 3	Parameters mapped on a uniform, earth-referenced, space-time grid
Level 4	Model output or results from analyses of lower level data (e.g., parameters derived from multiple measurements)
Survey	Summary or low fidelity data, often graphically presented, used for quicklook or data location
Support	Data acquired from non-AIM sources to supplement data analysis (e.g., NCEP data)
Collaborative	Data acquired through collaborative sources
Educational	Data products and other information intended for use by K-14 educators and students
Status	Data products that contain information about the AIM spacecraft or data products

## 7 SDS Concept

### 7.1 User Type Product Requirements

The SDS supports multiple users with different requirements. We have classified users into User Types based on their data requirements. *Table 7-1. User type and content class* presents a list of the user types and their various data requirements.

**Table 7-1. User type and content class**

User type	User Facility	Data Content Class
Mission Operations	MOC	Raw Telemetry Level 0 Status
Instrument Team	POC-DPC	Level 0 Status
AIM Science Teams	DPC PDC Co-I facility	Level 1-4 Survey Status Support Collaborative
Scientific	N/A	Level 2-4

Community		Survey Products Support Status
General Public	N/A	Survey Products Status
K-14 Educators	N/A	Educational Survey Status

A more detailed list is given in section 9.1.

## 7.2 Data Sources

Each SDS facility will be responsible for distributing data that it generates or acquires. The distribution points of the various content classes are listed in *Table 7-2. Data distributed by SDS facilities*. Note that navigating these various sources of data should be transparent to the user.

**Table 7-2. Data distributed by SDS facilities**

SDS Facility	Data Distributed
MOC	Raw telemetry Level 0 Support Status
POC-DPCs	Level 1-3 Survey Status
AIM PDC	Level 1-3 Metadata Status Educational Collaborative

## 7.3 System Architecture

### 7.3.1 Functional data flow

The following actions take place after data are received at the ground station:

1. The telemetry service function (at the MOC) distributes portions of the telemetry (Level 0 data) to the POC-DPCs and mission operations. This distribution can take place in both near-real time and in playback mode.
2. The Level 0 data are used at the POCs and mission operations for planning, command and assessment purposes. These functions are not within the scope of the SDS, however results of planning and assessment activities will serve as input to the SDS. Communications between mission operations and the command and assessment function of the POCs are not within the scope of the SDS.

3. Level 0 data, as well as planning and assessment products, are used to generate routine data products. This takes place at the MOC, the POCs, DPCs and the PDC. These products will be served by their producers. All communications required for product generation are within the scope of the SDS.
4. The products resulting from product generation are archived at the various facilities. These archives are used by the science teams for data analysis. Data analysis activities are not within the scope of the SDS. However, results of data analysis (data analysis products) will be transferred from the science teams into the appropriate archive.
5. Access to AIM data by the science community (including AIM users), K-14 educators, and the general public will be provided via the Internet. The Project Data Center will provide a central entry point to the AIM data dissemination capability by hosting a search facility containing meta-data for all AIM science data products. Each AIM SDS facility will maintain a web and ftp site serving the data products generated by that facility.

### 7.3.2 Long term archive preparation

The designated long-term archive for the AIM mission is the National Space Sciences Data Center (NSSDC). The NSSDC will maintain the AIM data only after mission closeout. During the mission access to the AIM data products and documents will be provided by the PDC and instrument DPCs. Data products from the various remote sites will be collected by the PDC and placed in the appropriate archive format for the NSSDC. The AIM Science Working Group will determine the contents of the archive.

The baseline long-term archive contents are as follows:

- Mission documentation and status data products
- The most current version of the routine data products
- Delivered software for the production of the most current version of the routine data products
- Algorithm Theoretical Basis Documents
- The most current version of the data analysis products
- Support products available only through the AIM program
- Utility software for data display and processing
- Bibliography of AIM related publications

There will be multiple versions of the long-term archive, depending on reprocessing activities. Only the final version will be delivered to the NSSDC; the other deliveries will serve as test beds for the archive production process. The deliveries are:

1. **Prototype version**, 1 year after launch. This version will contain only a subset of the final required products. This version will be used to evaluate data format compatibility and communications paths necessary for final archive production.
2. **Interim version**, during and at the close of spacecraft operations. This version will contain all of the required archival products that exist at the time of delivery to the archive.

3. **Final version**, 3 months after mission closeout. This version will be delivered to the NSSDC in December, 2008.

### 7.3.3 Shared software

The sharing of software among program elements is encouraged, particularly software for reading and processing data products. To this end, the SDS will provide a facility for shared software. While formal delivery of software will not be required, it is suggested that the authors of data products provide basic utilities for reading and processing their data products. These software products will generally be hosted by their author's facility.

The program will provide a set of guidelines for software to be shared, including a minimum documentation standard. The program will provide a structure for the exchange of software, submission guidelines and instructions for users. Authors of the software will identify the software to be shared and submit it for exchange. Guidelines and standards for shared software will be listed in this document when they are formulated.

It should be kept in mind that users of this shared software depend upon the good will of the supplier for support.

## 8 Internet Services

AIM program information will be disseminated to the community primarily through the Internet. Each SDS facility will maintain a web site with information and data products produced by or relevant to their instrument. The primary entry and coordination point will be hosted at the PDC. The major areas of the AIM web site are described below.

### 8.1 Mission Planning and Operations

This will be a link to the AIM MOC web site that will provide the ability to query spacecraft and instrument timelines as well as contact plans and reports. These timelines contain information about planned instrument modes and events. Coverage plots can be produced by the user via the STK software package using the spacecraft position and attitude supplemented by nominal instrument pointing. Contact plans and reports will also be served from this area, though the principle users of these reports will be the AIM instrument teams.

### 8.2 Data Products

This area will be used to distribute data to AIM users. This area will also allow users to browse and order data products. This area will be linked with the Mission Planning area to allow users to locate data that is of use to them. Selection criteria will include:

- Time range
- Data product description
- Instrument coverage
- Instrument modes, events and anomalies

Results of the selection will be a list of products that can be submitted as a data order. Instrument coverage selections will include the geographic coverage of the field of regard of the instruments, as well as the position of the spacecraft and solar position relative to the orbital plane.

### **8.3 Shared Software**

The shared software area will allow users to browse and order software submitted by SDS teams. This software should be used carefully and may not be supported by the SDS or its author. It should serve as a guideline for a user's own software development

### **8.4 Instrument/Science Teams**

Each instrument DPC will be represented in this area of the Web site. Pages in this area will be hosted and maintained by the instrument DPC. At minimum, each facility will provide a tutorial for using their data products, provide direct access to their product archives, and provide reprocessing status. In addition, each instrument DPC will provide a description of their instrument. There will be no formal 'look and feel' standards for these areas.

### **8.5 Educational and Public Outreach**

Materials generated by the AIM educational outreach effort will be hosted here. These materials may include K-14 directed mission descriptions and results, suggested student activities and student projects and curriculum enhancements based on the AIM mission and its data. These and other materials will be generated by the AIM Educational and Public Outreach (EPO) Team working in close cooperation with the AIM Science Team. The AIM EPO effort will be led by Hampton University. The portion of the AIM website dedicated to the AIM EPO effort will be hosted and maintained by the AIM PDC. Its structure, content and implementation will be the responsibility of the AIM EPO Team.

### **8.6 Personnel Directory**

A directory of AIM personnel will be hosted on the site, including email addresses and phone numbers. Only the information approved for publication will be placed here.

### **8.7 Mission Related Publications**

A reference list of publications related to the AIM mission will be cataloged here. Authors should email the reference citation information to the SDS Manager to include their publications in this bibliography.

## **9 Data Products**

### **9.1 Data Product Requirements**

#### **9.1.1 Science teams requirements**

- **9.1.1-1:** Each science team requires access to processed instrument data (level 1 - 4).
- **9.1.1-2:** Data quality information.
- **9.1.1-3:** A list of data products available from the AIM mission.
- **9.1.1-4:** Survey data products to aid in the location of data that are useful for analysis.
- **9.1.1-5:** A summary of data products produced and basic description of instrument state for each day of on orbit operations.



### **9.1.2 Scientific community requirements**

- **9.1.2-1:** Access to processed instrument data (level 2 - 4).
- **9.1.2-2:** Data quality information.
- **9.1.2-3:** A list of data products available from the AIM mission.
- **9.1.2-4:** Survey data products to aid in the location of data that are useful for analysis.
- **9.1.2-5:** A summary of data products produced and basic description of instrument state for each day of on orbit operations.
- **9.1.2-6:** Support data products to aid in the analysis of instrument data.

### **9.1.3 General public requirements**

- **9.1.3-1** Access to processed instrument data (level 2 - 4).
- **9.1.3-2:** Data quality information in broad terms including validation results.
- **9.1.3-3:** A list of data products available from the AIM mission.
- **9.1.3-4:** Survey data products to provide a basis for understanding the mission.
- **9.1.3-5:** Relevant description of research results of the AIM mission.

### **9.1.4 K-14 educators requirements**

- **9.1.4-1:** A list of data products available from the AIM mission
- **9.1.4-2:** Survey data products to provide a basis for understanding the mission
- **9.1.4-3:** Relevant description of research results of the AIM mission
- **9.1.4-4:** Materials that can be used in the classroom to aid in the understanding of the AIM mission and space-based observations in general
- **9.1.4-5:** Information on public access systems

## **9.2 Measurement Descriptions**

### **9.2.1 CIPS**

CIPS will produce on each orbit 25 panoramic high-resolution views of PMCs beneath the S/C. The scene recorded by CIPS during each .714 second integration will include Rayleigh scattered sunlight from altitudes near 50 km and Mie scattered sunlight by PMC particles near 82 km. The primary purposes of CIPS measurements are to provide the morphology of PMCs; measurements of GW activity in the presence of PMCs and globally in the upper stratosphere; and particle size information over the spatial and temporal evolution of PMCs.

### **9.2.2 CDE**

CDE will measure the mass and of each detected dust particle. This is a proxy measurement at the S/C altitude to estimate the deposition rate of cosmic material into the mesosphere.

### **9.2.3 SOFIE**

SOFIE will provide profiles of T, H<sub>2</sub>O, ice extinction (two channels), NO, CH<sub>4</sub>, O<sub>3</sub> and CO<sub>2</sub>. Aerosol extinction profiles will be retrieved for all eight spectral channels. Measurements will extend from 10 to 120 km with an instantaneous FOV of 1.3km

altitude resolution at the mesopause. The 15 orbits per day produce 30 occultations per day, 15 in each hemisphere

### 9.3 Data Product Description

The data products to be produced by the AIM mission are listed below in Table 9-1 AIM Data Products. The columns of the table are as follows:

**Product Name:** A unique name for the product.

**Product Description:** A short description of the product.

**Source:** The SDS facility responsible for the generation and distribution (during the mission) of the product.

**Generation Class:** The product generation classification is used to determine delivery schedules and aid in system monitoring. See section 6.1.1 for description of terms.

**Content Class:** The data content classification is used to refer to the type of data contained in the product. Data levels are adapted from the EOS Handbook. The data levels are supplemented with additional product content classes for products that are not easily classified by the data level scheme. See section 6.1.2 for description of terms.

**Time Available:** The amount of time required to generate and distribute the product, measured from the time of data acquisition of the spacecraft.

**Available to:** The list of user types and SDS facilities that the data is made available to on a regular basis.

**Requirement:** The requirements that this product satisfies.

**Reference:** A reference to a document providing details of the format, contents and size of this product.

**Table 9-1 AIM Data Products**

Product Name	Product Description	Source	Generation Class	Content Class	Time Available	Available to	Requirement	Reference
Mission Status Report	Daily Combined instrument status and spacecraft position	AIM MOC	On-demand	Status	96 hours	All	9.1.1-5 9.1.2-5	
Data Quality Report	Assessment of data quality	AIM MOC	On-demand	Status	96 hours	All	9.1.1-2 9.1.2-2 9.1.3-2	
Data Quality Report	Assessment of science data quality	DPCs	On-demand	Status	96 hours	All	9.1.1-2 9.1.2-2 9.1.3-2	
Data Product Catalog	Project wide listing of available data products	AIM PDC	On-demand	Status	96 hours	All	9.1.1-3 9.1.2-3 9.1.3-3	

Product Name	Product Description	Source	Generation Class	Content Class	Time Available	Available to	Requirement	Reference
							9.1.4-1	
CDE Level 1 Data	Time of impact, Pulse-height and engineering & housekeeping data	CDE DPC	Routine	Level 1	96 hours	All	9.1.1-1	
CDE Level 2 Data	Time of impact, mass[g] of the detected dust particle	CDE DPC	Routine	Level 2	96 hours	All	9.1.1-1 9.1.2-1 9.1.3-1	
CDE Level 3 Data	Impact rates [#hits/day] and size [mass resolved with factors of 2] distribution	CDE DPC	Routine	Level 3	96 hours	All	9.1.1-1 9.1.2-1 9.1.3-1	
CDE Level 4 Data	Spatial [1/4 orbit] and temporal distribution of impact rates and size [mass] distribution	CDE DPC	Routine	Level 4	96 hours	All	9.1.1-1 9.1.2-1 9.1.3-1	
CIPS Level 1A Data	Calibrated radiance images with data spikes removed	CIPS DPC	Routine	Level 1	96 hours	All	9.1.1-1	
CIPS Level 1B Data	Calibrated radiance images with data spikes removed registered to geophysical coordinates [lat, lon, time].	CIPS DPC	Routine	Level 1	96 hours	All	9.1.1-1	
CIPS Level 1C Data	Calibrated radiance images with Rayleigh scattered background subtracted	CIPS DPC	Routine	Level 1	96 hours	All	9.1.1-1	
CIPS Level 2A Data	Calibrated radiance images on uniform, earth referenced, space time grid.	CIPS DPC	Routine	Level 2	96 hours	All	9.1.1-1 9.1.2-1 9.1.3-1	
CIPS Level 2B Data	Calibrated radiance images for one orbit merged into single image	CIPS DPC	Routine	Level 2	96 hours	All	9.1.1-1 9.1.2-1 9.1.3-1	
CIPS Level 3A Data	Daily merged image, each orbital merged image for a day merged into single image	CIPS DPC	Routine	Level 3	96 hours	All	9.1.1-1 9.1.2-1 9.1.3-1	
CIPS Level 3B Data	Cloud season movie. Daily merged images combined into an animated sequence.	CIPS DPC	Analysis	Level 3		All	9.1.1-1 9.1.2-1 9.1.3-1	
CIPS Level 4CP Data	Cloud properties, extinction, particle size, brightness, extent, particle area, water content	CIPS DPC	Analysis	Level 4		All	9.1.1-1 9.1.2-1 9.1.3-1	
CIPS Level 4WD Data	Wave dynamics. Image and scale length determination of dynamical features related to gravity wave phenomena	CIPS DPC	Analysis	Level 4		All	9.1.1-1 9.1.2-1 9.1.3-1	
SOFIE Level 1A Data	Detector measurements for all 16 channels and 8 difference measurements, solar vector, sun sensor pixel values, mirror position values and spacecraft PVAT data.	SOFIE DPC	Routine	Level 1	96 hours	All	9.1.1-1	

Product Name	Product Description	Source	Generation Class	Content Class	Time Available	Available to	Requirement	Reference
SOFIE Level 1B Data	Corrected (offsets, drift, imbalance and FOV mismatch) detector full and difference measurements, true elevation angle to solar top edge, apparent solar extent (angular), apparent elevation angle for science FOV, refraction angle for solar top & bottom edges, apparent tangent altitude for solar top and bottom edges, T,P profiles, tangent point lat & lon, line of sight vector.	SOFIE DPC	Routine	Level 1	96 hours	All	9.1.1-1	
SOFIE Level 2 Data	Primary absorber mixing ratios (CO <sub>2</sub> , CH <sub>4</sub> , NO <sub>2</sub> , H <sub>2</sub> O, O <sub>3</sub> ), 16 aerosol extinction profiles, T, P [0.3 km sampling, 150km to cloud top, 30 profiles/day] Vertical resolution: <ul style="list-style-type: none"> <li>• Gases 1km</li> <li>• T&amp;P ≤ 3.5km</li> <li>• PMC 1km</li> </ul>	SOFIE DPC	Routine	Level 2	96 hours	All	9.1.1-1 9.1.2-1 9.1.3-1	
SOFIE Level 3 Data	Pressure vs. latitude, pressure vs. longitude cross sections. Weekly, monthly, seasonal maps of PMs, gases	SOFIE DPC	Analysis	Level 3		All	9.1.1-1 9.1.2-1 9.1.3-1	
CVO Level 2A Data	SOFIE profiles of atmosphere/ice transmission	AIM PDC	Routine	Level 2	96 hours	All	9.1.1-1 9.1.2-1 9.1.3-1	
CVO Level 2B Data	CIPS calibrated radiance images in and near the Common Volume	AIM PDC	Routine	Level 2	96 hours	All	9.1.1-1 9.1.2-1 9.1.3-1	
CVO Level 3A Data	SOFIE LOS in CIPS images	CIPS DPC	Analysis	Level 3		All	9.1.1-1 9.1.2-1 9.1.3-1	
CVO Level 3B Data	cloud extinction	CIPS DPC	Analysis	Level 3		All	9.1.1-1 9.1.2-1 9.1.3-1	
CVO Level 3C Data	scattering phase function for all clouds in common volume	CIPS DPC	Analysis	Level 3		All	9.1.1-1 9.1.2-1 9.1.3-1	
CVO Level 3D Data	Temperature, water vapor and pressure profile	SOFIE DPC	Analysis	Level 3		All	9.1.1-1 9.1.2-1 9.1.3-1	
CVO Level 3E Data	NO, O <sub>3</sub> , CO <sub>2</sub> , CH <sub>4</sub> , H <sub>2</sub> O	CIPS DPC	Analysis	Level 3		All	9.1.1-1 9.1.2-1 9.1.3-1	
CVO Level	Particle size (mode radius)	CIPS	Analysis	Level 4		All	9.1.1-1	

Product Name	Product Description	Source	Generation Class	Content Class	Time Available	Available to	Requirement	Reference
4A Data	and sigma derived from CIPS & SOFIE inverted data	DPC					9.1.2-1 9.1.3-1	
CVO Level 4B Data	Number density of cloud particles	CIPS DPC	Analysis	Level 4		All	9.1.1-1 9.1.2-1 9.1.3-1	
CVO Level 4C Data	Water content	CIPS DPC	Analysis	Level 4		All	9.1.1-1 9.1.2-1 9.1.3-1	
CVO Level 4D Data	Particle size	CIPS DPC	Analysis	Level 4		All	9.1.1-1 9.1.2-1 9.1.3-1	
CVO Level 5 Data	Gravity wave dynamic derived from SOFIE profile of tracers and CIPS images	CIPS DPC	Analysis	Level 5		All	9.1.1-1 9.1.2-1 9.1.3-1	

### 9.4 Requirements Allocation

Requirement	Product
9.1.1-1	CDE Level 1 CDE Level 2 CDE Level 3 CDE Level 4 CIPS Level 1 CIPS Level 2 CIPS Level 3 CIPS Level 4 SOFIE Level 1 SOFIE Level 2 SOFIE Level 3 CVO Level 2 CVO Level 3 CVO Level 4
9.1.1-2	Data Quality Report
9.1.1-3	Data Product Catalog
9.1.1-4	SOFIE Level 3
9.1.1-5	Mission Status Report
9.1.2-1	CDE Level 1 CDE Level 2 CDE Level 3 CDE Level 4 CIPS Level 1 CIPS Level 2 CIPS Level 3 CIPS Level 4 SOFIE Level 1 SOFIE Level 2

Requirement	Product
	CVO Level 2 CVO Level 3 CVO Level 3
9.1.2-2	Data Quality Report
9.1.2-3	Data Product Catalog
9.1.2-4	SOFIE Level 3
9.1.2-5	Mission History Catalog
9.1.2-6	
9.1.3-1	CDE Level 1 CDE Level 2 CDE Level 3 CDE Level 4 CIPS Level 1 CIPS Level 2 CIPS Level 3 CIPS Level 4 SOFIE Level 1 SOFIE Level 2 CVO Level 2 CVO Level 3 CVO Level 3
9.1.3-2	Data Quality Report
9.1.3-3	Data Product Catalog
9.1.3-4	SOFIE Level 3
9.1.3-5	
9.1.4-1	Data Product Catalog
9.1.4-2	
9.1.4-3	
9.1.4-4	
9.1.4-5	

### 9.5 Data Rates

Table 9-2 Data Product Rates gives an estimated rate (mbytes/day) at which data is captured or produced for the various processing levels. Table 9-3 Common Volume Observation Data Rates gives the anticipated rate (mbytes/day) at which Common Volume Observation data is collected from each instrument, combined and stored at the PDC.

**Table 9-2 Data Product Rates**

	SOFIE	CIPS	CDE	Total
<b>Level 0</b>	25	512	0.0009	537.0009
<b>Level 1</b>	9	5324.8	0.0018	5333.8018
<b>Level 2</b>	9	1228.8	0.0018	1237.8018
<b>Level 3</b>	0.5	307.2	0.0018	307.7018

<b>Level 4</b>	N/A	51.2	0.003	51.203
<b>Total</b>	43.5	7424	0.0093	7467.5093

**Table 9-3 Common Volume Observation Data Rates**

	<b>SOFIE</b>	<b>CIPS</b>	<b>CDE</b>	<b>Total</b>
<b>Level 1</b>	9			9
<b>Level 2</b>	9	76		85
<b>Level 3</b>	N/A	35		35
<b>Level 4</b>	N/A	70		70
<b>Total</b>	18	181		199

## Appendix A - Data Product Specification

The goal of the Data Product Specification is to provide a uniform description of all the data products being exchanged for AIM. There should be a data product specification for each product that is generated and/or exchanged among AIM facilities. These specifications will be assembled and made available as a data location aid, as well as assisting in interface definition.

Field Name	Required / Optional	Notes
<b>Product Name</b>	R	A unique name for the product
<b>Source</b>	R	The facility generating the product
<b>File Naming Convention</b>	R	
<b>Description/Purpose</b>	R	Free text describing what the product is for
<b>Data Product Version</b>	R	Required for SDS controlled products only
<b>Data Generation Classifier</b>	R	[routine   analysis   on-demand]
<b>Data Content Classifier</b>	R	[level n   survey   support   education   status   collaborative]
<b>Generation Trigger</b>	O	Event causing this product to be generated
<b>Frequency</b>	O	Only required for regularly delivered products
<b>File Size</b>	O	Approximate upper limit of file size
<b>File Type</b>	R	[netCDF   ASCII   other]
<b>Contents</b>	O	ASCII files – description of field contents and formats NetCDF – CDL file for this product Other – format/content definition
<b>Intended Recipient</b>	O	See section 7.1 for supported users
<b>Comments</b>	O	Free text, any additional descriptions
<b>Data Product Version Description</b>	R	Required for SDS products if no reference is available
<b>Product Format Version Description</b>	R	Required for SDS products if no reference is available
<b>Software Major Version Description</b>	R	Required for SDS products if no reference is available
<b>Input/Cal Major Version Description</b>	R	Required for SDS products if no reference is available
<b>DQ-Confidence</b>	R	Confidence level of data product type [High   Reasonable   Low]
<b>DQ-Version</b>	R	[Current   Preliminary   Supercede   Test   Special]
<b>DQ-Review</b>	R	Level of review product version has undergone [Full   Partial   Inference   None]
<b>DQ-Uses</b>	R	Appropriate Audience for data type [Survey   Quicklook   Detail   Trend   Educational]
<b>Parameters</b>	R	List of science parameters contained in this file



Field Name	Required / Optional	Notes
<b>Instrument Mode</b>	R	Instrument modes in effect in this file
<b>Max Altitude Covered</b>	R	Maximum value of altitude coverage
<b>Min Altitude Covered</b>	R	Minimum altitude coverage
<b>Reference</b>	O	Reference to another document describing this product

### Description of Field Value choices:

**Data Generation Classifier** – see section 6.1.1

**Data Content Classifier** – see section 6.1.2

### DQ-Confidence:

High – The investigator feels this is an excellent measurement with little or no spurious artifacts.

Reasonable – The investigator feels this is a good measurement; however it should be handled with the same care as other remote sensing data sets. It is recommended you consult with the investigator before using this data set.

Low – There may be important problems with this data set. Contact the investigator before using this data.

### DQ-Version:

Current – This version represents the best data currently available.

Preliminary – This version has been verified and is intended to become the current version.

Supersede – This version has been superseded by a more recent version.

Test – This version is new and not completely verified.

Special – This version has limited applicability.

### DQ-Review:

Full – The data set has been examined and validated. Its overall quality and contents are well known.

Partial – The data set has had a cursory examination and has been partially validated. Its overall quality and contents are known, but a full review has not been conducted.

Inference – The data set had been validated by a process that has been demonstrated to produce data of a known quality. No review of this individual product has been done.

None – The data set has not been reviewed and its quality is unknown.

### DQ-Uses:

Survey – Appropriate for data location and qualitative purpose only

Quicklook – Appropriate for exploratory analysis but not intended to be used for high precision analyses.

Detail – Appropriate for most forms of quantitative analysis.

Trend – Appropriate for tracking geophysical trends. The data set generally covers long periods of time and will be processed from a large set of quantitatively accurate data sets with stable calibration.

---

Educational – Appropriate for use by K-14 educators and students.

## **Appendix B - AIM Versions and Revisions**

### **B.1 Data Product Revision Number**

The file naming convention for all data products should contain data product revision number, which should be a 2-digit number beginning with 01, indicating the number of times the product has been regenerated with the same processing software and input data files. This number is not related to processing version but rather it indicates how many times this particular file has been generated. Typically, this number is 01. Sometimes data entry errors, transmission problems or other difficulties may require the product to be re-released.

### **B.2 Data Product Version Number**

The file naming conventions should also contain the data product version number, which will be a 3-digit number starting at 001. This number indicates the number of times the content or format of this data product type has changed. The data product version number should be incremented whenever one or more of the following version numbers change.

- Product Format Version
- Major Software Version
- Major Input/Cal Version

#### **B.1.1 Product Format Version Number**

The product format version number is a 3-digit number, starting at 001, indicating the number of times the format of the product type has changed. Any change to the product that might require modifications to the software that reads the product should cause an increment in the format version. These changes include, but are not limited to, addition or modification of global attribute types, changes in data type, new variables and changes in units.

#### **B.1.2 Software Version Number**

The software version number consists of two 2-digit numbers in the format xx.yy. Each 2-digit number starts with 01 and the combination is separated by a period (e.g. 02.04). The first 2-digit number (xx) represents the major software version and is incremented each time there are major changes in the processing algorithms that are likely to affect the quality of the data. The second 2-digit number (yy) represents the minor software version and is incremented for bug fixes, input interface changes, or other software changes that do not substantially impact the quality of the resulting data.

#### **B.1.3 Input/Cal Version Number**

Like the Software Version Number, the input/cal version number consists of a major and minor version number delimited by a period, e.g. xx.yy, where xx is the major version and yy is the minor version. The major and minor version are used the same way as with the Software Version Number.

## Appendix C - Acronyms and Definitions

<b>A</b>	
AIM	Aeronomy of Ice in the Mesosphere
<b>C</b>	
CDE	Cosmic Dust Experiment
CIPS	Cloud Imaging and Particle Size
CO-I	Co-Investigator
CPU	Central Processing Unit
CU	University of Colorado
<b>D</b>	
DMP	Data Management Plan
DPC	Data Processing Center
<b>E</b>	
E/PO	Education and Public Outreach
EOS	Earth Observing System
<b>F</b>	
FOV	Field-of-View
FTP	File Transfer Protocol
FTS	Fourier Transform Spectroscopy
<b>G</b>	
GATS	G&A Technical Software
GIF	Graphics Interchange Format
GSE	Ground Support Equipment
GSFC	Goddard Space Flight Center
GW	Gravity Waves
<b>H</b>	
HTTP	Hypertext Transport Protocol
HU	Hampton University
<b>I</b>	
I&T	Integration and Test
IR	Infrared
ISO	International Standards Organization
ICD	Interface Control Document
<b>J</b>	
JPEG	Joint Photographic Experts Group
<b>L</b>	
LASP	Laboratory for Atmospheric and Space Physics
<b>M</b>	
MOC	Mission Operations Center
MODS	Mission Operations Data Systems
MPEG	Moving Pictures Expert Group
<b>N</b>	
NASA	National Aeronautics and Space Administration
NetCDF	Network Common Data Format
NSSDC	National Space Sciences Data Center
<b>O</b>	

---

OASIS	Operations and Science Instrument Support
OSS	Office of Space Science
<b>P</b>	
PA	Product Assurance
PDC	Project Data Center
PI	Principal Investigator
PM	Program Manager
PMC	Polar Mesospheric Clouds
PNG	Portable Network Graphics
POC-DPC	Payload Operations Center and Data Processing Center
<b>Q</b>	
QA	Quality Assurance
<b>S</b>	
SADIE	Stereoscopic and Dynamics Imaging Instrument
S/C	Spacecraft
SDL	Space Dynamics Laboratory
SDS	Science Data Systems
SMTP	Simple Mail Transport Protocol
SOFIE	Solar Occultation for Ice Experiment
SSH	Secure Shell
SSL	Secure Socket Layer
SSR	Solid State Recorder
STDN	Space Tracking and Data Network
STRV	Space Technology Research Vehicle
SSU	Stratospheric Sounding Unit
<b>T</b>	
TIMED	Thermosphere, Ionosphere, Mesosphere, Energetics and Dynamics
<b>U</b>	
UV	Ultraviolet

---